



Laden Container Handler
Reachstacker
Capacity 42000 to 45000 kg
C 4230 TL – C 4531 CH SERIES 357

Safety

On-board microprocessors constantly measure load weight, boom angle and extension; immediately responding to potential overload conditions by warning the operator and cutting-out lift and telescopic reach functions while allowing the operator to return the machine to a safe operational condition.

Performance

The combination of a high power, low speed – high torque engine, matched with an electronically controlled 4-speed transmission, together with an advanced hydraulic system, manage the efficient use of energy, with maximised speed of operation while reducing the wear on hydraulic components.

Comfort

The cabin, equipped to provide the operator with a low stress and spacious working environment is provided with comfortable and intuitive ergonomics which are vital in creating the optimised working conditions necessary for sustained high performance operation.

Linde Material Handling

Linde

Reliability

The high performance of the Linde Reachstacker is matched by the robustness of its construction. The high quality, heavy duty drive line components are designed to ensure maximum performance and durability. Heavy-duty main structural elements provide stress relief over the load bearing areas, thus ensuring lifelong product integrity.

Productivity

The central positioning of the operators cabin optimises the visibility to the load handler for loading and unloading operations, and also around the machine when working in confined operating areas; Combining the operator comfort and component performance with intuitive ergonomics further enhances the ease of operation which is a main characteristic of this product.

Technical data

Characteristics	1.1	Manufacturer	LINDE	LINDE	LINDE	LINDE	LINDE	
	1.2	Model designation	C 4230 TL / 4	C 4230 TL / 5	C 4531 TL / 4	C 4531 TL / 5	C 4234 TL / 4	
	1.3	Power unit: battery, diesel, LP gas, mains power	Diesel	Diesel	Diesel	Diesel	Diesel	
	1.4	Operation: manual, pedestrian, stand-on, seated, order picker	Rider Seated	Rider seated	Rider seated	Rider seated	Rider seated	
	1.5	Load capacity (L1, L2, L3)	Q (kg)	42000/30000/16000	42000/30000/16000	45000/31000/16000	45000/31000/16000	42000/34000/17000
	1.6	Load centre, First row (L1)	c (mm)	1760	1760	1760	1760	1760
		Load centre, Second row (L2)	c (mm)	3810	3810	3810	3810	3810
		Load centre, Third row (L3)	c (mm)	6250	6250	6250	6250	6250
	1.8	Axle centre to fork face (L1-1/2 high)	x (mm)	2800 / 2600	2800 / 2600	2800 / 2600	2800 / 2600	2800 / 2600
1.9	Wheelbase	y (mm)	6400	6400	6400	6400	6400	
Weights	2.1	Service weight	kg	70400	70400	71400	71400	73200
	2.2	Axle load with load, front/rear (L1)	kg	97180 / 15220	97180 / 15220	101900 / 14500	101900 / 14500	97030 / 18170
		Axle load without load, front/rear (L2)	kg	-	-	-	-	-
	2.3	Axle load without load, front/rear (L1)	kg	35900 / 34500	35900 / 34500	36400 / 35000	36400 / 35000	36100 / 37100
	Axle load without load, front/rear (L2)	kg	-	-	-	-	-	
Wheels & tyres	3.1	Tyres, front/rear. SE = (superelastic), P = (pneumatic)	P / P	P / P	P / P	P / P	P / P	
	3.2	Tyre size, front	18.00 x 25 / 40pr	18.00 x 25 / 40pr	18.00 x 25 / 40pr	18.00 x 25 / 40pr	18.00 x 25 / 40pr	
	3.3	Tyre size, rear	18.00 x 25 / 40pr	18.00 x 25 / 40pr	18.00 x 25 / 40pr	18.00 x 25 / 40pr	18.00 x 25 / 40pr	
	3.5	Wheels, number, front/rear (x = driven)	4x/2	4x/2	4x/2	4x/2	4x/2	
	3.6	Track width, front	b10 (mm)	3030	3030	3030	3030	3030
	3.7	Track width, rear	b11 (mm)	2786	2786	2786	2786	2786
Dimensions	4.1	Telescopic boom lift angle, Raised/lowered	α/β (°)	56/0	61/0	56/0	61/0	56/0
	4.2	Height telescopic boom lowered	h1 (mm)	4900	4900	4900	4900	4900
	4.4	Lift (L1, L2, L3)	h3 (mm)	13400/11120/6850	15900/14100/11350	13400/11120/6850	15900/14100/11350	13400/11120/6850
	4.5	Height, telescopic boom extended	h4 (mm)	16560	19000	16560	19000	16560
	4.7	Height of overhead guard (cabin)	h6 (mm)	3900	3900	3900	3900	3900
	4.8	Height, operators seat /stand-on platform	h7 (mm)	2840	2840	2840	2840	2840
	4.12	Towing coupling height	h10 (mm)	600	600	600	600	600
	4.15	Twistlock height lowered	h13 (mm)	1495	1495	1495	1495	1495
	4.19	Overall length with attachment	l1 (mm)	11618	11618	11618	11618	11618
	4.20	Overall length	l2 (mm)	8408	8408	8408	8408	8408
	4.21	Overall width	b1/b2 (mm)	4180 / 3400	4180 / 3400	4180 / 3400	4180 / 3400	4180 / 3400
	4.24	Width of attachment 20' / 40'	b3 (mm)	6050 / 12150	6050 / 12150	6050 / 12150	6050 / 12150	6050 / 12150
	4.31	Ground clearance minimum	m1 (mm)	345	345	345	345	345
	4.32	Ground clearance, centre of wheelbase	m2 (mm)	300	300	300	300	300
	4.33	Stacking aisle 20' container	Ast (mm)	10225	10225	10225	10225	10225
	4.34	Stacking aisle 40' container	Ast (mm)	13050	13050	13050	13050	13050
	4.35	Turning radius	Wa (mm)	8605	8605	8605	8605	8605
4.36	Minimum pivoting point distance	b13 (mm)	3400	3400	3400	3400	3400	
Performance	5.1	Travel speed, with/without load	km/h	22/25	22/25	22/25	22/25	22/25
	5.2	Lift speed, with/without load	m/s	0.28/0.39	0.28/0.39	0.28/0.39	0.28/0.39	0.28/0.39
	5.3	Lowering speed, with/without load	m/s	0.39/0.39	0.39/0.39	0.39/0.39	0.39/0.39	0.39/0.39
	5.5	Tractive force, with/without load	1 kph kN	325/-	325/-	325/-	325/-	325/-
	5.6	Maximum tractive force, with/without load	kN	370/-	370/-	370/-	370/-	370/-
	5.7	Climbing ability, with/without load	1 kph %	29/-	29/-	29/-	29/-	29/-
	5.8	Maximum climbing ability, with/without load	%	33.9/34.5	33.9/34.5	33.9/34.5	33.9/34.5	33.9/34.5
	5.9	Acceleration time, with/without load	s	-	-	-	-	-
	5.10	Service brake		Wet disc	Wet disc	Wet disc	Wet disc	Wet disc
	6.4	Battery voltage, rated capacity	V/Ah	24V (2x 12 / 143)	24V (2x 12 / 143)	24V (2x 12 / 143)	24V (2x 12 / 143)	24V (2x 12 / 143)
Drive	7.1	Engine manufacturer /type	Cummins QSM 11	Cummins QSM 11	Cummins QSM 11	Cummins QSM 11	Cummins QSM 11	
	7.2	Engine performance according to ISO 1585	kW	246	246	246	246	
	7.3	Rated speed	1/min	2100	2100	2100	2100	
	7.4	Number of cylinders/displacement	/cm ³	6 / 10820	6 / 10820	6 / 10820	6 / 10820	
	7.5	Fuel consumption according to VDI cycle	l/h	-	-	-	-	
Other	8.1	Type of drive control	Torque conv. 4/4	Torque conv. 4/4	Torque conv. 4/4	Torque conv. 4/4	Torque conv. 4/4	
	8.2	Working pressure for attachments	bar	160	160	160	160	
	8.3	Oil flow for attachments	l/min	-	-	-	-	
	8.4	Noise level, at operator's ear, Overhead guard/Cab	dB (A)	74	74	74	74	
	8.5	Trailer coupling, design/type DIN	\varnothing (mm)	50	50	50	50	

AST Stacking aisle

	4	5
20'	12700	12900
40'	14400	14600

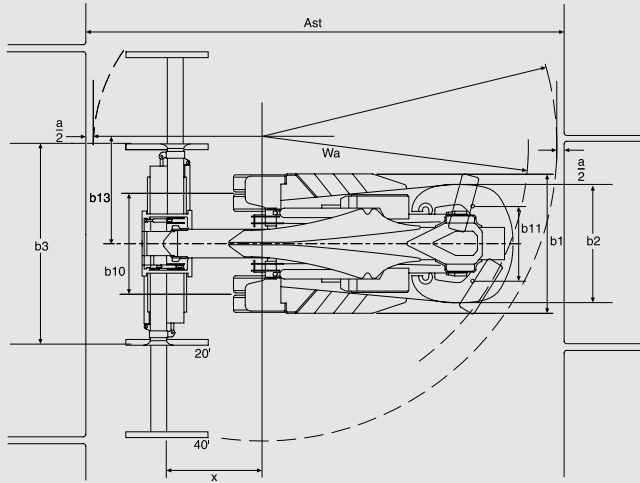

AST Travelling aisle

	4	5
20'	10225	10225
40'	13050	13050

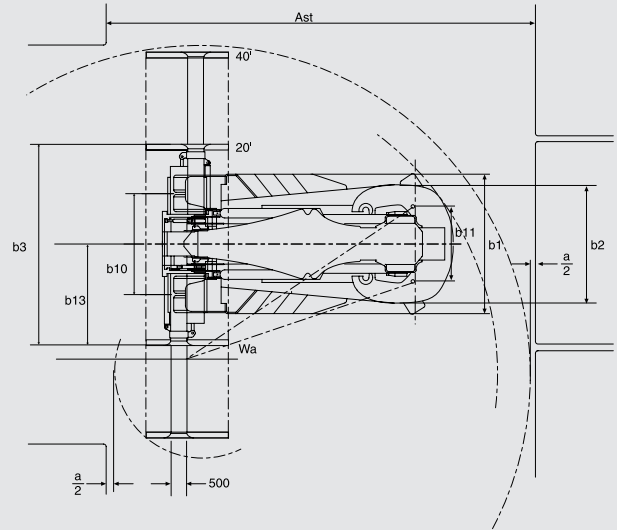

Rotation	30°	45°	30°	45°
Model capacity	42000 kg	42000 kg	45000 kg	45000 kg
Distance (a)	4200 mm	4100 mm	4200 mm	4100 mm
Capacity (a)	25000 kg	25000 kg	28000 kg	28000 kg
Distance (b)	-	5300 mm	-	5300 mm
Capacity (b)	-	20000 kg	-	20000 kg

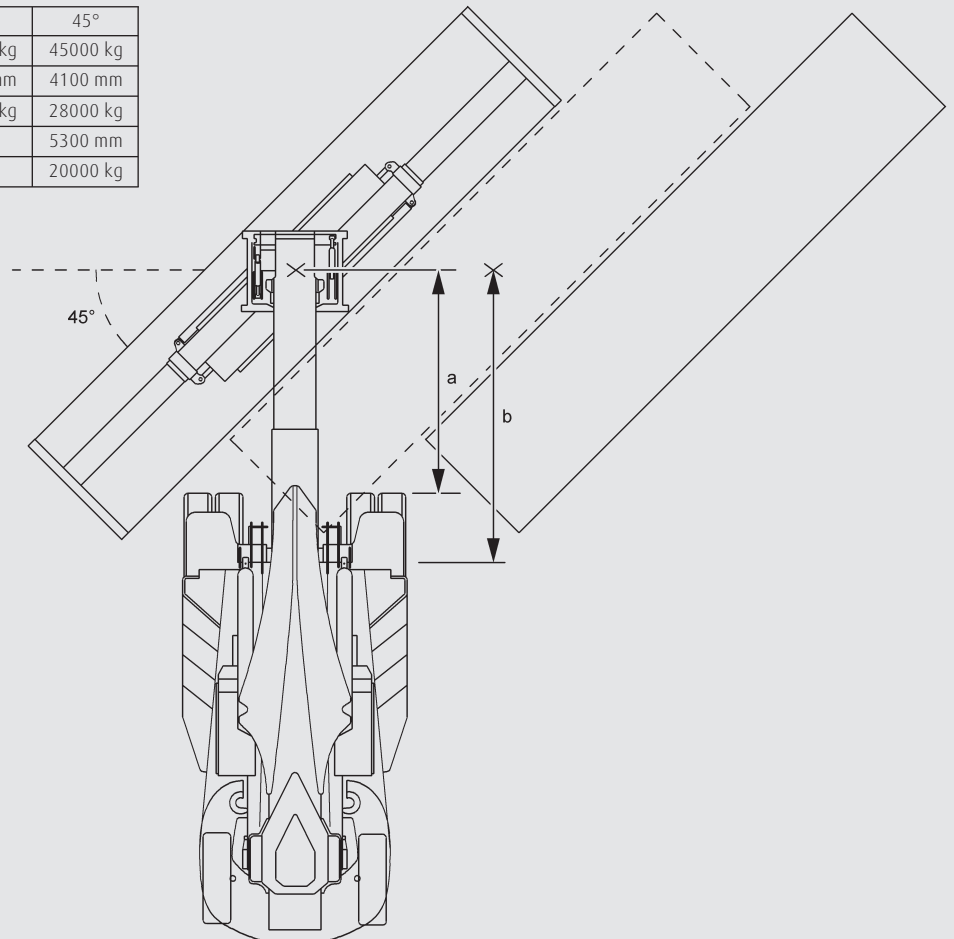

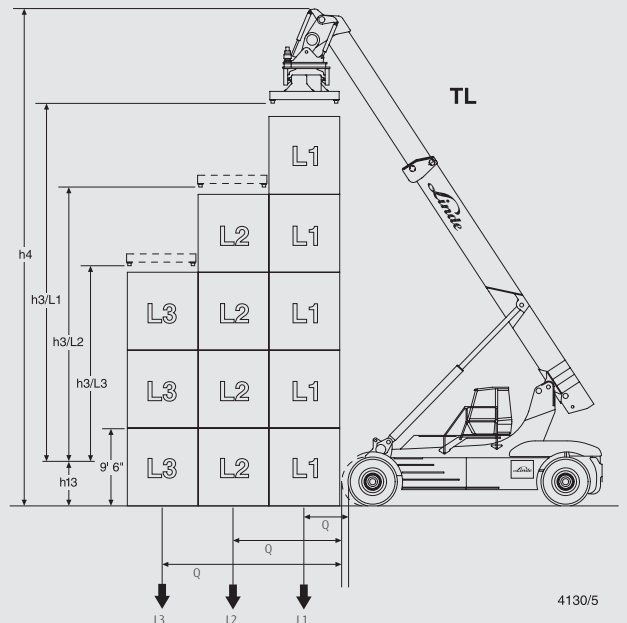
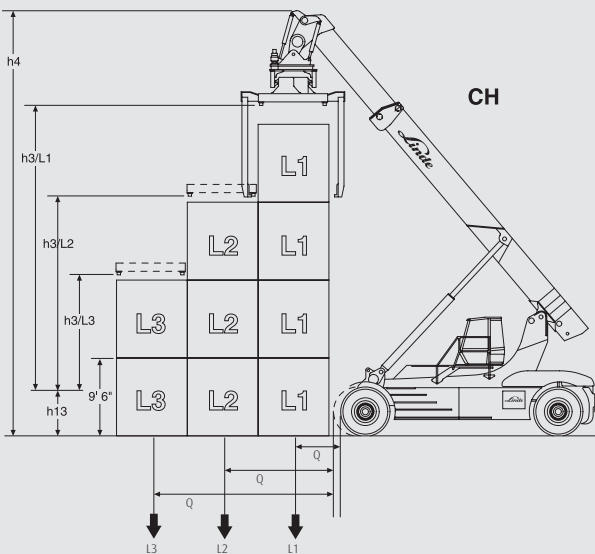
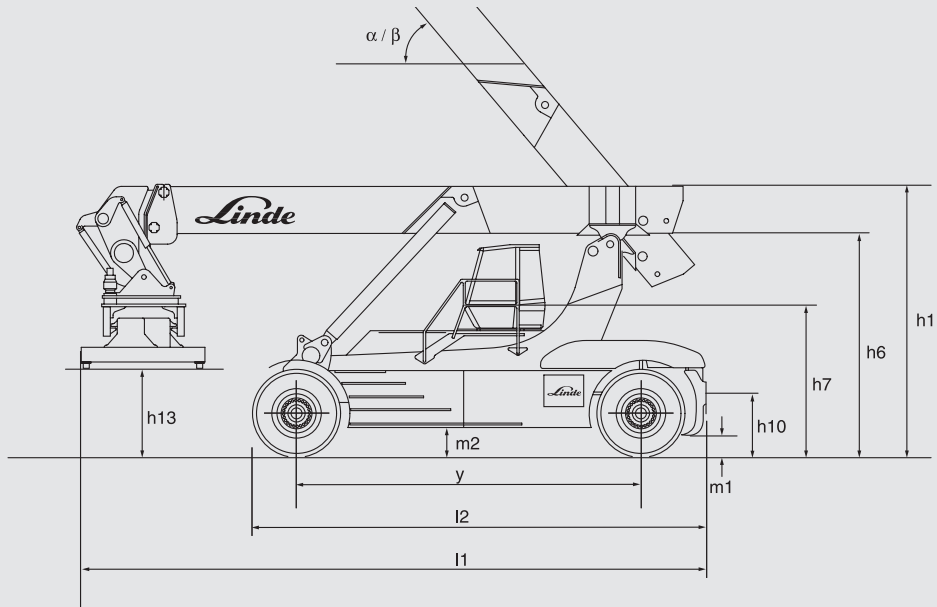
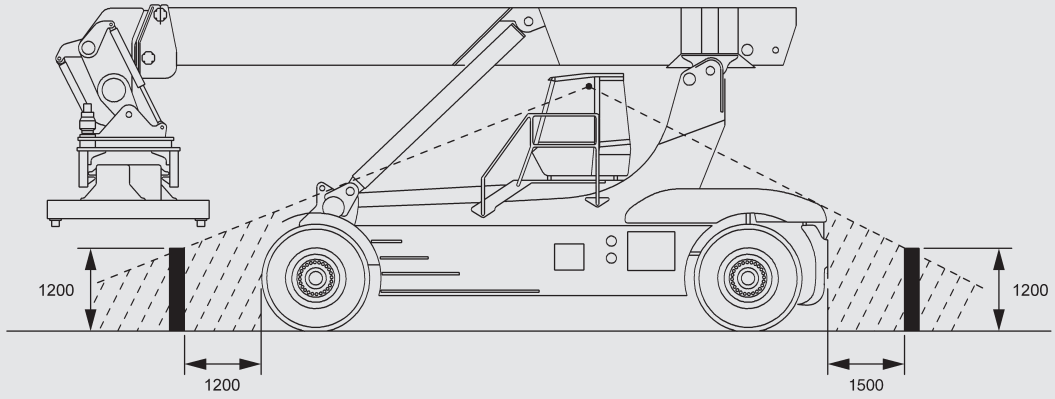

Container-Load weight and lift height (under twistlocks)

Toplift Handler – TL

C 4230 TL / 4 8' 6"

37			5 high	13400 mm
42	30		4 high	11120 mm
42	30			
42	30	16	2 high	6850 mm
42	30	16		

L1	L2	L3
----	----	----

C 4230 TL / 5 8' 6"

27			6 high	15900 mm
37	25		5 high	14100 mm
42	30	16	4 high	11350 mm
42	30	16		
42	30	16		
42	30	16		

L1	L2	L3
----	----	----

C 4230 TL / 4 9' 6"

42			4 high	13400 mm
42	30		3 high	11120 mm
42	30	16	2 high	6850 mm
42	30	16		

L1	L2	L3
----	----	----

C 4230 TL / 5 9' 6"

34			5 high	15900 mm
42	30		4 high	14100 mm
42	30	16	3 high	11350 mm
42	30	16		
42	30	16		

L1	L2	L3
----	----	----

Toplift Handler – TL

C 4531 TL / 4 8' 6"

45			5 high	13400 mm
45	31		4 high	11120 mm
45	31			
45	31	16	2 high	6850 mm
45	31	16		

L1	L2	L3
----	----	----

C 4531 TL / 5 8' 6"

35			6 high	15900 mm
45	25		5 high	14100 mm
45	31	16	4 high	11350 mm
45	31	16		
45	31	16		
45	31	16		

L1	L2	L3
----	----	----

C 4531 TL / 4 9' 6"

45			4 high	13400 mm
45	31		3 high	11120 mm
45	31	16	2 high	6850 mm
45	31	16		

L1	L2	L3
----	----	----

C 4531 TL / 5 9' 6"

41			5 high	15900 mm
45	31		4 high	14100 mm
45	31	16	3 high	11350 mm
45	31	16		
45	31	16		

L1	L2	L3
----	----	----

Toplift Handler – TL

C 4234 TL / 4 8' 6"

37			5 high R1	13400 mm
42	34		4 high R2	11120 mm
42	34			
42	34	17	2 high R3	6850 mm
42	34	17		

L1	L2	L3
----	----	----

C 4234 TL / 5 8' 6"

27			6 high R1	15900 mm
37	25		5 high R2	14100 mm
42	34	17	4 high R3	11350 mm
42	34	17		
42	34	17		
42	34	17		

L1	L2	L3
----	----	----

C 4234 TL / 4 9' 6"

42			4 high	13400 mm
42	34		3 high	11120 mm
42	34	17	2 high	6850 mm
42	34	17		

L1	L2	L3
----	----	----

C 4234 TL / 5 9' 6"

34			5 high	15900 mm
42	31		4 high	14100 mm
42	34	17	3 high	11350 mm
42	34	17		
42	34	17		

L1	L2	L3
----	----	----

Toplift Handler – TL

C 4535 TL / 4 8' 6"

45			5 high R1	13500 mm
45	35		4 high R2	11220 mm
45	35	19	3 high R3	6950 mm
45	35	19		
45	35	19		

L1	L2	L3
----	----	----

C 4535 TL / 5 8' 6"

35			6 high R1	16000 mm
45	32		5 high R2	14200 mm
45	35	19	4 high R3	11550 mm
45	35	19		
45	35	19		
45	35	19		

L1	L2	L3
----	----	----

C 4535 TL / 4 9' 6"

45			4 high R1	13500 mm
45	35		3 high R2	11220 mm
45	35	19	2 high R3	6950 mm
45	35	19		

L1	L2	L3
----	----	----

C 4535 TL / 5 9' 6"

41			5 high R1	16000 mm
45	35		4 high R2	14200 mm
45	35	19	3 high R3	11550 mm
45	35	19		
45	35	19		

L1	L2	L3
----	----	----

Combination Handler – CH

C 4026 CH / 4 8' 6"

40	26		4 high R1	13075 mm
40	26		4 high R2	10800 mm
40	26	12	2 high R3	6550 mm
40	26	12		

L1	L2	L3
----	----	----

C 4026 CH / 5 8' 6"

33	22		5 high R1	15575 mm
40	26	12	5 high R2	13775 mm
40	26	12	4 high R3	11025 mm
40	26	12		
40	26	12		

L1	L2	L3
----	----	----

C 4026 CH / 4 9' 6"

40			4 high R1	13780 mm
40	26		3 high R2	10800 mm
40	26	12	2 high R3	6550 mm
40	26	12		

L1	L2	L3
----	----	----

C 4026 CH / 5 9' 6"

29			5 high R1	15575 mm
40	26		4 high R2	13780 mm
40	26	12	3 high R3	11050 mm
40	26	12		
40	26	12		

L1	L2	L3
----	----	----

Combination Handler – CH

C 4030 CH / 4 8' 6"

40	30		4 high R1	13075 mm
40	30		4 high R2	10800 mm
40	30	13	2 high R3	6550 mm
40	30	13		

L1	L2	L3
----	----	----

C 4030 CH / 5 8' 6"

33	22		5 high R1	15575 mm
40	30	13	4 high R2	13780 mm
40	30	13	5 high R2	11050 mm
40	30	13		
40	30	13		

L1	L2	L3
----	----	----

C 4030 CH / 4 9' 6"

40			4 high R1	13075 mm
40	30		3 high R2	10800 mm
40	30	13	2 high R3	6550 mm
40	30	13		

L1	L2	L3
----	----	----

C 4030 CH / 5 9' 6"

29			5 high R1	15575 mm
40	26		4 high R2	13780 mm
40	30	13	3 high R3	11050 mm
40	30	13		
40	30	13		

L1	L2	L3
----	----	----

Combination Handler – CH

C 4531 CH / 4 8' 6"

43			5 high R1	13175 mm
45	31		4 high R2	10900 mm
45	31			
45	31	15	2 high R3	6650 mm
45	31	15		

L1	L2	L3
----	----	----

C 4531 CH / 5 8' 6"

41	27		5 high R1	15675 mm
45	31	15	5 high R2	13880 mm
45	31	15	4 high R3	11150 mm
45	31	15		
45	31	15		

L1	L2	L3
----	----	----

C 4531 CH / 4 9' 6"

45			4 high R1	13175 mm
45	31		3 high R2	10900 mm
45	31	15	2 high R3	6650 mm
45	31	15		

L1	L2	L3
----	----	----

C 4531 CH / 5 9' 6"

36			5 high R1	15675 mm
45	31		4 high R2	13880 mm
45	31	15	3 high R3	11150 mm
45	31	15		
45	31	15		

L1	L2	L3
----	----	----

Standard equipment/Optional equipment

Standard equipment

Fully equipped driver's cabin with hinged doors; wipers and washers for windscreen, rear screen and overhead screen, heater and demister

Hydraulically driven, forward moving cabin with rear safety exit window (CH – Combi-Handler models)

Hydraulic-suspension comfort-class seat with wide range of adjustment

Proportional hydraulic function lever enabling precise load positioning with automatic anti-stall function

Adjustable-angle steering wheel

Effortless hydrostatic power steering; lock-to-lock at standstill

Engine intake air cleaner with integrated safety element

High performance hydraulic filters preserving maximum purity of oil for long life of all hydraulic components

On-demand working hydraulics, oil supply by twin-pump installation

Overload safety device; measures load weight and position

Data transfer modem for remote truck diagnostics and fault warning

Comprehensive head-up display; monitors all key components

Central master warning light

Modern diesel engine with electronically controlled single-rail fuel injection system meeting European and international emission regulations

Heavy-duty automatic 4-speed electronic powershift transmission with integrated safety protection; downshift, forward/reverse interlock

Robust double hub reduction drive axle, incorporating oil bath type multi-disk brakes with zero maintenance requirements

Regenerative hydraulic system for lift and extension system

4 high stacking boom

LCD display including fuel gauge, clock, hour meter and control lamps, lamps for all important truck functions

Abundant storage space for writing, materials, beverage cans, etc.

Pneumatic tyres

Telescopic toplift spreader (TL – Toplift models)

Telescopic toplift spreader with folding lifting arms and manual extension stops at 20' – 24' – 30' – 40' (CH – Combi-Handler models)

Rotation 95 degrees / 185 degrees

Sideshift 800mm +/-

Road lighting with boom support mounted reverse lights and audible warning

Front mudguard mounted working lights 2 pairs

Boom support mounted rear left / right working lights

Boom mounted working lights 2 pairs

Reverse driving mirrors – chassis mounted

Interior rearview mirror

Battery isolator switch with removeable key

Low step left & right (CH – Combi-Handler models)

Automatic handbrake

Optional equipment

Hydraulically driven, forward moving cabin with rear safety exit window (TL – Toplift models)

Climate control

Cabin pre-heat system – fuel burning or electrical

Central greasing system – chassis, chassis & boom, chassis boom & spreader

High level air intake – cabin (heater system only)

Heated operators seat

Additional seat

Tinted glass

Sliding window – right side

Air suspension seat with compressor

Vertical lift

Joystick steering or mini-wheel steering systems

Electrical socket in cab – 12volt

5 high stacking boom

Heated reverse driving mirrors

Panoramic interior mirror

Radio with compact disc unit and speakers

Spreader mounted working lights 2 or 4

Rotating beacon or flashing beacon

Manual extension stops 20/24/40 or 20/24/30/40 or 20/30/40 (TL – Toplift models)

Sun blind – front and top

Fire extinguisher (2 kg)

Engine coolant heater

Hydraulic tank heater

Brake tank heater

Counterweight mounted camera with monitor

Handrails – on steps left & right, on chassis top right

Low step left & right (TL – Toplift models)

Custom paintwork

Features



Load sensing hydraulics

- Highly efficient variable displacement pumps
- Metered oil for function selected
- Synchronised with truck load and operational conditions for optimised performance



Operators compartment

- Fully adjustable high quality seat
- Forced air heating and ventilation system
- Adjustable steering column
- Adjustable armrest and hydraulic control console
- Optimised position of operator control instrumentation

Linde load management

- IQAN managed operating system
- CanBus linked major components
- Controlled truck and load condition
- LCD display
- Constant fault monitoring



Comprehensive display

- Languages – 8 european
- Engine – water temperature, oil pressure, tachometer, engine torque
- Transmission – oil pressure and temperature
- Hydraulic & Brake – oil temperature
- Fuel – level and rate of use
- Electrical – battery state
- Air – cleaner restriction warning

Power and drive system

- Powerful engine – high torque at low speed
- 4 speed electronically controlled transmission
- Wide-track drive axle with wet disk brake system
- Drive line protection with built-in operational inhibitors: downshifting, reverse direction change, gear change ration

Stable, robust chassis

- Heavy duty main chassis for optimised stress handling
- Robust boom construction for secure load handling
- Heavy gauge side panels providing impact protection

Modern powerfull engine

- Diesel motor Stage II emissions
- Turbocharger and Intercooler
- 6 cylinder – 11 litre
- 246 kW (330 bhp) @ 2100 rpm
- maximum torque 1674 @ 1100 rpm



Telescopic spreader

- Rotation 95 / 185 degrees
- Twin sideshift cylinders
- Sideshift 800 mm +/-
- Internal extension cylinders
- Slope pile +/- 2 degrees
- Twin brake hub units
- Twistlock safety interlock