

Counterbalanced Electric Stacker for Explosion-hazard Areas 1000 and 1200 kg



375

The L10AC/Ex and L12AC/Ex tiller-controlled electric counterbalanced stackers for service in explosion-hazard areas incorporate all the benefits of the standard-production models L10AC and L12AC. Flexibility in handling deck pallets, box pallets and other loads is equal to that of a rider-seat lift truck. Other distinguishing features are high performance characteristics, optimized reliability and safety, simple operation and exemplary ergonomic design.

The Ex-stacker conform to ATEX European Directive 94/9 EC (EN 1755) or international regulations for use in explosion-hazardous areas.

They are **type-tested** by the Institut National de l'Environnement Industriel et des Risques – INERIS – with Certificate INERIS 14362/98, Linde offers Ex-specified trucks for use in the following classified areas:

- Zone 1 IIB T4 or T5 Atex to Ineris Certificate No. 14362/98
- Zone 2 IIB T4 or T5 Atex
- Areas requiring explosive materials protection to ZH 1/168

Essential components of these explosion proof trucks are identical with the corresponding standard Linde models. The following description highlights the modifications incorporated in the version for Zone 1 application.

Ergonomic tiller control

All controls are made explosion proof (Class d) without compromising the proven ergonomic qualities. In all other respects the tiller arm is identical to the standard truck version, including maximum protection for the operator's hands. Electronic control components are efficiently protected by the rugged cast aluminium housing.

Explosion proof traction motor

The traction motor is explosion proof, enclosed together with the brake by a sturdy cast steel housing, and its specifications are for the most part identical to the standard truck version. Surface heating is safety limited by a temperature monitor.

Pressure-tight lift motor

The lift motor is installed in a separate pressure-tight casing and has its own high-temperature cut-out to control surface heating within the defined safe maximum.

Efficient control

Linde's proven LTM control system, designed to give powerful acceleration and millimetre-accurate positioning, has been carried over to these special-duty versions. All control devices and the circuitry are integrated in a pressure-tight casing. If the truck remains idle for 9 minutes, it is automatically shut-down by a separate economizer. This ensures that the truck does not remain activated unintentionally and enhances the overall safety standard.

Standard equipment

Standard high-visibility mast, overall height 1912 mm, lift height 2750 mm, two-cylinder mast lift 3 degrees forward and 8 degrees backward. Series-wound 1.2 kW traction motor, 3.0 kW hydraulic motor. Infinitely variable LTM traction control. Countercurrent braking incurring virtually no wear or power loss activated by reversing the drive control switch, mechanical brake acting on the motor shaft controlled by tiller arm position. Insulation monitoring as standard for Zone 1; continuous measurement and readout of insulation resistance. Safety starting lock, safety tiller head, horn, emergency stop switch. Traction wheel and load wheels fitted with hard-wearing, electrically conductive polyurethane tyres. Battery compartment suitable for 24 V PzS 240 Ah battery.

Options

Standard high-visibility masts for lift height from 3250 mm to 4250 mm, duplex high-visibility masts with 1250 to 2000 mm free lift for lift heights from 2750 to 4250 mm. Alternative fork lengths, 800 to 1200 mm. All-in-one display (operating hours recorder and battery discharge indicator).

Other options available on request.

LINDE		Electric Stacker		Data sheet for material handling equipment		EGI		VDI 2198	
March 2003		Designation VDI 3586				to VDI 3586			
Characteristics	1.1	Manufacturer				Linde		Linde	
	1.2	Model designation				L 10ACEx		L 12ACEx	
	1.3	Power unit: battery, diesel, petrol, LP gas, mains power				Battery		Battery	
	1.4	Operation: manual, pedestrian, stand-on, seated, order picker				Pedestrian		Pedestrian	
	1.5	Load capacity		Q (kg)		1000		1200	
	1.6	Load centre		c (mm)		500		500	
	1.8	Load centre distance		x (mm)		140		140	
	1.9	Wheelbase		y (mm)		1390		1390	
	Weights	2.1	Service weight		kg		1930		1930
2.2		Axle load with load, front / rear		kg		2872/ 564		2872/ 564	
2.3		Axle load without load, front / rear		kg		952/1300		952/1300	
Wheels and Tyres	3.1	Tyres, front / rear (SE = CS superelastic, P = pneumatic)				VU / VU		VU / VU	
	3.2	Tyre size, front		mm		250 x 105		250 x 105	
	3.3	Tyre size, rear		mm		180 x 100		180 x 100	
	3.4	Additional wheels (Dimensions)				-		-	
	3.5	Wheels, number front / rear (x = driven)				1 x / 2		1 x / 2	
	3.6	Track width, front		b10 (mm)		-		-	
	3.7	Track width, rear		b11 (mm)		785		785	
Dimensions	4.2	Height of mast, lowered		h1 (mm)		1905		1905	
	4.3	Free lift		h2 (mm)		150		150	
	4.4	Lift		h3 (mm)		2750		2750	
	4.5	Height of mast, extended		h4 (mm)		3330		3330	
	4.6	Initial lift		h5 (mm)		-		-	
	4.9	Height of tiller in operating position min./max.		h14 (mm)		880/1240		880/1240	
	4.15	Height lowered		h13 (mm)		52		52	
	4.19	Overall length		l1 (mm)		2914		2914	
	4.20	Length to fork face		l2 (mm)		1764		1764	
	4.21	Overall width		b1/b2 (mm)		885		885	
	4.22	Fork dimensions		s/e/l (mm)		52x92x1154		52x92x1154	
	4.25	Fork spread min./max.		b5 (mm)		850/850		850/850	
	4.32	Ground clearance, centre of wheelbase		m2 (mm)		70		70	
	4.33	Aisle width with pallets 1000 x 1200 across forks		Ast (mm)		3443		3443	
	4.34	Aisle width with pallets 800 x 1200 along forks		Ast (mm)		3553		3553	
4.35	Turning radius		Wa (mm)		1955		1955		
Performance	5.1	Travel speed, with / without load		km/h		4.04/4.36		4.04/4.36	
	5.2	Lifting speed, with / without load		m/s		0.125/0.178		0.125/0.178	
	5.3	Lowering speed, with / without load		m/s		0.454/0.238		0.454/0.238	
	5.7	Climbing ability, with / without load		%		4.1/ 7.9		4.1/ 7.9	
	5.8	Maximum climbing ability, with / without load		%		12.1/20.9		12.1/20.9	
5.10	Service brake				mechanical		mechanical		
Drive	6.1	Drive motor (S2 60 min.)		kW		1.2		1.2	
	6.2	Lift motor (S3 15 %)		kW		3.0		3.0	
	6.3	Battery according to IEC				254-2		254-2	
	6.4	Battery voltage, rated capacity (K 5)		V/Ah		345		345	
	6.5	Battery weight		kg		310		310	
8.1	Type of drive control				LTM transistor control		LTM transistor control		

Subject to modification in the interests of progress. Illustrations and technical details not binding for actual construction. All dimensions subject to usual tolerances.

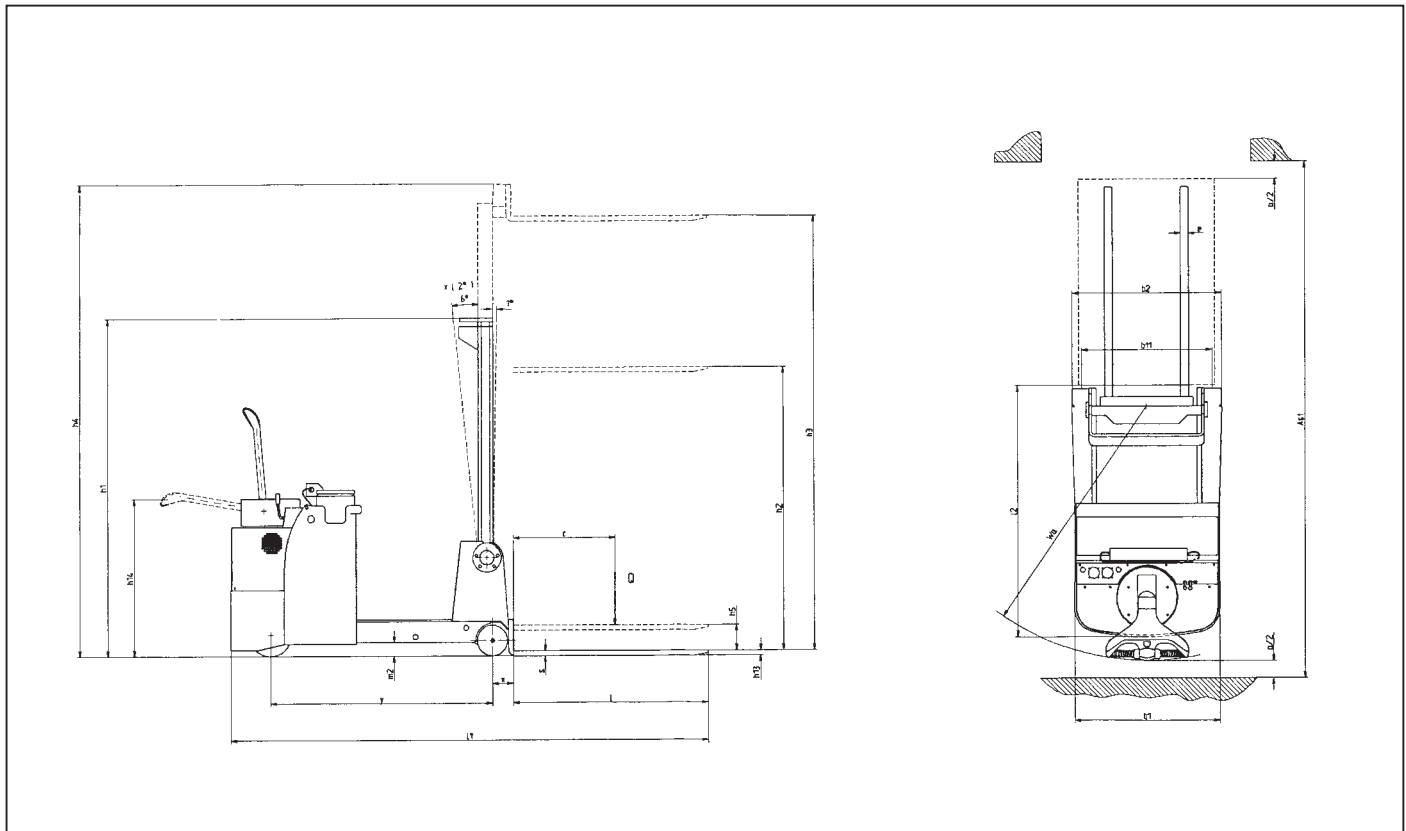

Linde AG, Linde Material Handling Division
 Postfach 100136, 63701 Aschaffenburg, Germany
 Phone +49-6021-99-0, Fax +49-6021-99-1570
 www.linde-forklifts.com, info@linde-forklifts.com



Printed in Germany · 135 · e · 1 · 0403 · A & P · Ind. B