

## Standard and optional equipment

### Standard equipment

#### General

Three-wheel configuration  
 Overall width (reach legs) 1366mm (R 14G & R 16G),  
 1470mm (R 20G)  
 Linde Load Control for lift/lower, reach, tilt and sidelift  
 Linde twin accelerator pedals  
 Full suspension PVC seat with electric lumbar support  
 Comprehensive digital instrument display  
 6.5 kW maintenance-free AC drive motor  
 14 kW maintenance-free AC lift motor  
 Superelastic load wheel tyres  
 Cushion rubber drive wheel tyre  
 Self-adjusting service brakes  
 Linde proportional 180° electric steering  
 Clearview triplex tilting mast lift 4955mm (R 14G & R 16G),  
 4655mm (R 20G)  
 Fork length 1150 mm  
 Standard colour scheme vermilion and charcoal grey

#### Batteries and chargers

48 V, 560 Ah to 700 Ah  
 Wide selection of chargers available to suit application

#### Electronics

Linde Digital Control system (LDC) incorporating  
 CAN bus technology

### Optional equipment

Triplex tilting mast lifts to 6955 mm (R 14G & R 16G),  
 7455mm (R 20G)  
 Single accelerator pedal, automotive layout with left  
 foot interlock  
 Alternative fork lengths  
 Fork extensions  
 Load backrest  
 Single axis joysticks for all hydraulic functions  
 Audible traction alarm  
 Seat heater

#### Safety

Monitoring system stops truck in the event of  
 traction, steering or lift failure  
 Three independent braking systems  
 All-wheel braking  
 Emergency isolator  
 Seat-actuated traction interlock  
 Electric horn  
 Automatic slowdown at maximum lift  
 Automatic slowdown at end of reach travel  
 Protective polycarbonate screen between control console  
 and mast  
 Battery locking interlock  
 Electrical and hydraulic overload protection  
 Overhead guard

#### Mast

Torsion-resistant tilting triplex clearview mast  
 Integral sideshift  
 High residual capacities

#### Fabric seat material

Seat back extension  
 Variable electronic drive unit brake  
 Ambient cab  
 PIN access  
 LFM  
 Working lamps/beacons  
 Additional hydraulic circuit  
 Mesh or polycarbonate protection on overheard guard  
 Battery on rollers  
 Battery roller stand  
 Alternative colour schemes

Other options available on request.



**Electric Reach Trucks**  
**Capacity 1400 kg – 2000 kg**  
**R 14 G, R 16 G, R 20 G Active** SERIES 115-03

Linde Material Handling 

### Safety

Designed for optimum operator comfort and safety, The Linde Active 'G' range can perform a dual-purpose role in both internal and external applications. Unique drive unit suspension and large tyres enable it to operate effectively outside on uneven surfaces, loading and unloading road vehicles, for example; as well as storing and retrieving loads in narrow aisle warehouses.

### Performance

The Linde Active drive concept employing advanced Linde control technology translates the powerful output of the AC motors into seamless productivity. A comprehensive selection of batteries ensures that each truck is precisely matched to the demands of individual applications.

### Comfort

A perfect interface between operator and truck has been achieved with the Linde ergonomic design concept, including spacious cab, comfort-class seat with lumbar support and intuitive layout of all controls. The operator's working environment ensures optimum performance.

## Features

#### Superb working environment

→ Linde Load Control: precise, effortless fingertip control of all mast movements  
 → Ergonomic, full suspension comfort-class seat fully adjustable to the operator's personal preferences  
 → Adjustable steering console

#### Manoeuvrability

→ A short wheelbase, compact chassis dimensions and smooth electric power steering ensure easy and efficient manoeuvring



#### Stability

→ Chassis designed and built for maximum strength and durability  
 → Heavy-duty construction materials and components provide low centre of gravity for stability and high residual capacities

#### Linde clearview mast

→ Torsion-resistant clearview triplex tilting mast with integral sideshift

#### Linde twin accelerator pedals

→ Effortless forward/reverse selection places minimal demands on operator  
 → Operator is able to maintain high efficiency and productivity levels



#### Precision

→ Assured manoeuvring with Linde twin accelerator pedals  
 → Precision load handling with Linde Load Control  
 → Responsive, progressive and adjustable electric steering with essential 'road feel'  
 → Digital instrument display for instant read out of truck status  
 → Excellent visibility of load and surrounding environment



#### Wheels and tyres/suspension

→ Large diameter for operation on uneven ground  
 → Unique drive unit suspension to reduce vibration and road shocks

#### Batteries

→ Capacity to suit every type of application: 48 V, 560 Ah to 700 Ah  
 → Quick and easy battery change



#### Servicing

→ Maintenance-free AC traction and lift motors  
 → Configurable Linde Digital Control system  
 → Incorporates diagnostic technology  
 → Easy service access  
 → Up to 1000 operating hours between services

Linde Material Handling GmbH, Postfach 10 0136, 63701 Aschaffenburg, Germany  
 Phone +49.60.21.99-0, Fax +49.60.21.99-15 70, www.linde-mh.com, info@linde-mh.com

Linde Material Handling 

# Technical data

		LINDE					
		R 14 G ACtive	R 16 G ACtive	R 20 G ACtive			
Characteristics	1.1	Manufacturer	LINDE	LINDE	LINDE		
	1.2	Model designation	R 14 G ACtive	R 16 G ACtive	R 20 G ACtive		
	1.3	Power unit: battery, diesel, petrol, LP gas, mains power	Battery	Battery	Battery		
	1.4	Operation: manual, pedestrian, stand-on, seated, order picker	Seated	Seated	Seated		
	1.5	Load capacity	Q (kg)	1400 <sup>3)</sup>	1600 <sup>3)</sup>	2000 <sup>3)</sup>	
Weights	1.6	Load centre	c (mm)	600/500	600/500	600/500	
	1.8	Axle centre to fork face	x (mm)	326 <sup>2)</sup>	321 <sup>2)</sup>	471 <sup>2)</sup>	
	1.9	Wheelbase	y (mm)	1380	1380	1530	
	2.1	Service weight	kg	3288	3288	3414 <sup>4)</sup>	
	2.3	Axle load without load, front (drive)/rear (load)	kg	1962/1326	1962/1326	2216/1198 <sup>4)</sup>	
	2.4	Axle load, fork outreached with load, front (drive)/rear (load)	kg	723/3965	675/4213	450/4964 <sup>4)</sup>	
	2.5	Axle load, fork retracted with load, front (drive)/rear (load)	kg	1697/2991	1738/3150	2016/3398 <sup>4)</sup>	
	3.1	Tyres, front (drive)/rear (load) C = cushion, SE = superelastic		C/SE	C/SE	C/SE	
	3.2	Tyre size, front (drive) wheel		18 x 8 x 12 <sup>1/8</sup>	18 x 8 x 12 <sup>1/8</sup>	18 x 8 x 12 <sup>1/8</sup>	
	3.3	Tyre size, rear (load) wheel		180/60-10	180/60-10	180/60-10	
Wheels and tyres	3.5	Wheels, number front (drive)/rear (load) (x = driven)		1x/2	1x/2	1x/2	
	3.6	Track width, front (drive)	b10 (mm)	0	0	0	
	3.7	Track width, rear (load)		1245	1245	1265	
	4.1	Mast/fork carriage tilt, forward/backward	$\alpha/\beta$ (°)	2/4	2/4	2/4	
	4.2	Height of mast, lowered	h1 (mm)	2225	2225	2225	
	4.3	Free lift	h2 (mm)	1361	1361	1361	
	4.4	Lift	h3 (mm)	4955 <sup>5)</sup>	4955 <sup>5)</sup>	4655 <sup>5)</sup>	
	4.5	Height of mast, extended	h4 (mm)	5695	5695	5395	
	4.7	Height of overhead guard (cab)	h6 (mm)	2246	2246	2246	
	4.8	Height of seat, minimum/maximum	h7 (mm)	1076/1166	1076/1166	1076/1166	
Dimensions	4.10	Height of reach legs	h8 (mm)	476	476	476	
	4.19	Overall length	l1 (mm)	2506	2511	2511	
	4.20	Length to fork face	l2 (mm)	1356 <sup>2)</sup>	1361 <sup>2)</sup>	1361 <sup>2)</sup>	
	4.21	Overall width	b1/b2 (mm)	1234/1366	1234/1366	1234/1470	
	4.22	Fork dimensions	s/e/l (mm)	40 x 80 x 1150	45 x 100 x 1150	45 x 100 x 1150	
	4.23	Fork carriage to DIN 15173, class/form A, B		2A	2A	2A	
	4.24	Width of fork carriage	b3 (mm)	767	767	767	
	4.25	Fork spread, minimum/maximum	b5 (mm)	216/597	216/597	216/597	
	4.26	Width between reach legs	b4 (mm)	922	922	922	
	4.28	Reach travel	l4 (mm)	594 <sup>2)</sup>	594 <sup>2)</sup>	744 <sup>2)</sup>	
	4.31	Ground clearance, mast	m1 (mm)	90	90	90	
	4.32	Ground clearance, centre of wheelbase	m2 (mm)	145	145	145	
	4.33	Aisle width, pallet 1000 x 1200 across forks	Ast (mm)	2785 <sup>2)</sup>	2789 <sup>2)</sup>	2833 <sup>2)</sup>	
	4.34	Aisle width, pallet 800 x 1200 along forks	Ast (mm)	2844 <sup>2)</sup>	2849 <sup>2)</sup>	2865 <sup>2)</sup>	
	4.35	Turning radius	Wa (mm)	1683	1683	1833	
4.37	Length of chassis	l7 (mm)	1912	1912	2062		
Performance	5.1	Travel speed, with/without load	km/h	12.5/12.5 <sup>4)</sup>	12.5/12.5 <sup>4)</sup>	12.5/12.5 <sup>4)</sup>	
	5.2	Lifting speed, with/without load	m/s	0.42/0.66 <sup>5)</sup>	0.40/0.66 <sup>5)</sup>	0.32/0.51 <sup>5)</sup>	
	5.3	Lowering speed, with/without load	m/s	0.55/0.45 <sup>4)</sup>	0.55/0.45 <sup>4)</sup>	0.55/0.45 <sup>4)</sup>	
	5.4	Reach speed, with/without load	m/s	0.15/0.15 <sup>4)</sup>	0.15/0.15 <sup>4)</sup>	0.15/0.15 <sup>4)</sup>	
	5.7	Climbing ability, with/without load, 30 minute rating	%	4.5/8.2	4.5/8.2	4.5/8.2	
	5.8	Maximum climbing ability, with/without load, 5 minute rating	%	10/10	10/10	10/10	
	5.9	Acceleration time, with/without load	s	5.5/4.8 <sup>5)</sup>	5.5/4.8 <sup>5)</sup>	5.8/5.0 <sup>5)</sup>	
	5.10	Service brake		Hydraulic/electric	Hydraulic/electric	Hydraulic/electric	
	Drive	6.1	Drive motor, 60 minute rating	kW	6.5	6.5	6.5
		6.2	Lift motor, 15% rating	kW	14	14	14
6.3		Battery to DIN/IEC		43531C/254-2	43531C/254-2	43531C/254-2	
6.4		Battery voltage/rated capacity (5 h)	V/Ah	48/560 <sup>2)</sup>	48/560 <sup>2)</sup>	48/560 <sup>2)</sup>	
6.5		Battery weight ( $\pm 5\%$ )	kg	939	939	939	
6.6		Power consumption to VDI cycle	kWh/h	<sup>6)</sup>	<sup>6)</sup>	<sup>6)</sup>	
Other	8.1	Type of drive control		Electronic/stepless	Electronic/stepless	Electronic/stepless	
	8.2	Working pressure for attachments	bar	200	200	200	
	8.3	Oil flow for attachments	l/min	6.5	6.5	6.5	
	8.4	Noise level at operator's ear	dB (A)	63 <sup>7)</sup>	63 <sup>7)</sup>	63 <sup>7)</sup>	

<sup>1)</sup> For all other heights, see table  
<sup>2)</sup> Alternative batteries increase length to fork face, 90° stacking aisle widths and affects other dimensions  
<sup>3)</sup> Capacity may be reduced for high lifts  
<sup>4)</sup> Traction, lift, lower and reach speeds and weights may vary with alternative lift heights

<sup>5)</sup> Reduced speed and acceleration on request  
<sup>6)</sup> Refer to manufacturer for figures  
<sup>7)</sup> Figure shown is without cab

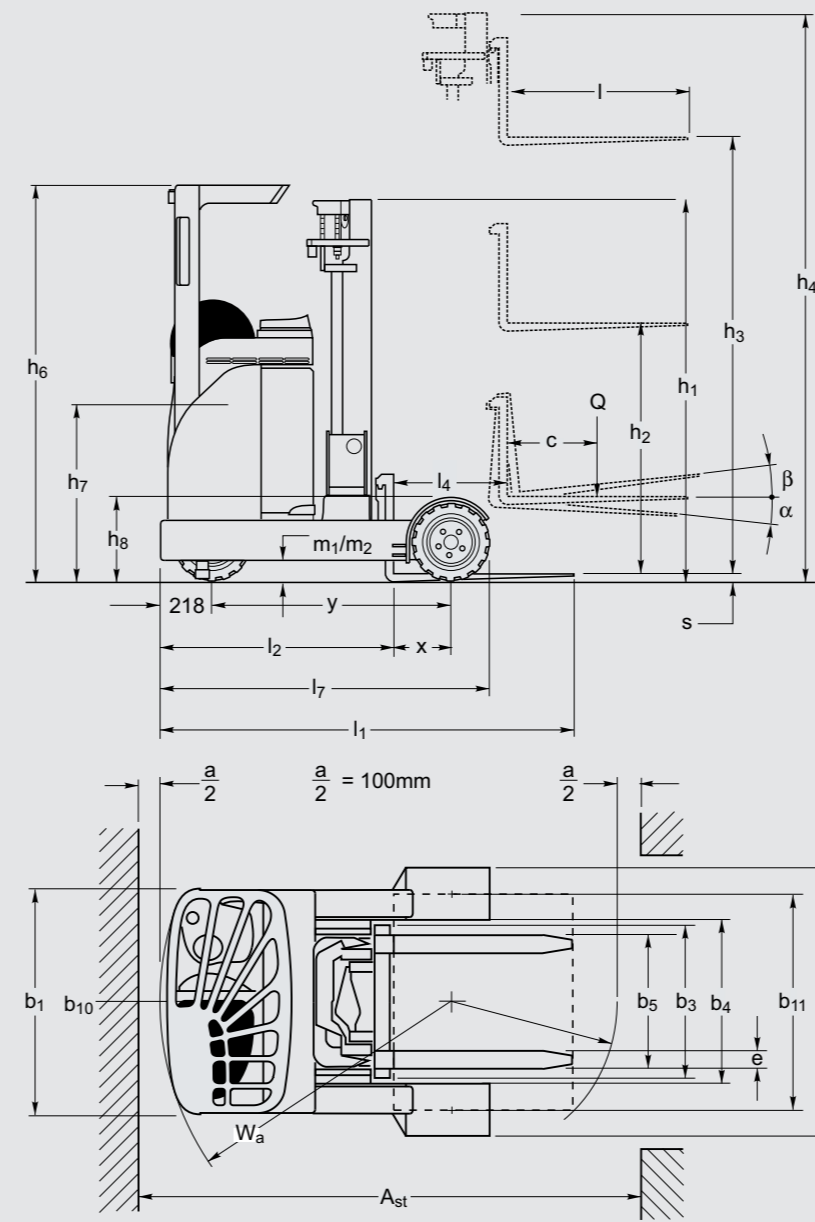

Triplex mast – R 14 G and R 16 G									
Lift	<b>h3</b>	4 955	5 155	5 755	6 255	6 655	6 955	-	-
Height of mast, lowered	<b>h1</b>	2 225	2 491	2 491	2 925	2 925	2 925	-	-
Height of mast, extended	<b>h4</b>	5 695	5 895	6 495	6 995	7 395	7 695	-	-
Free lift	<b>h2</b>	1 361	1 627	1 627	2 061	2 061	2 061	-	-

Triplex mast – R 20 G									
Lift	<b>h3</b>	4 655	4 655	5 155	5 755	6 255	6 655	6 955	7 455
Height of mast, lowered	<b>h1</b>	2 225	2 491	2 491	2 925	2 925	2 925	3 391	3 391
Height of mast, extended	<b>h4</b>	5 395	5 395	5 895	6 495	6 995	7 395	7 695	8 195
Free lift	<b>h2</b>	1 361	1 627	1 627	2 061	2 061	2 061	2 527	2 527

Alternative lift heights available on request. Lift height = **h3 + s + 10 mm**

